

# NOTICE

## 2007 GM DEUCE CLAMP INSTALLATION SPECIAL INSTRUCTIONS



### CAUTION

Incorrect clamping can cause damage to the vehicle. Clamp **ONLY** where **TWO** layers of sheet metal are present. Do not over tighten clamps.

- 1** **Correct clamping location:** Place clamps in the location shown below. See owners manual for positioning the side rails correctly. With side rail held in place, attach clamps. **If your truck has factory or aftermarket side rail protectors, see detail A & B.**

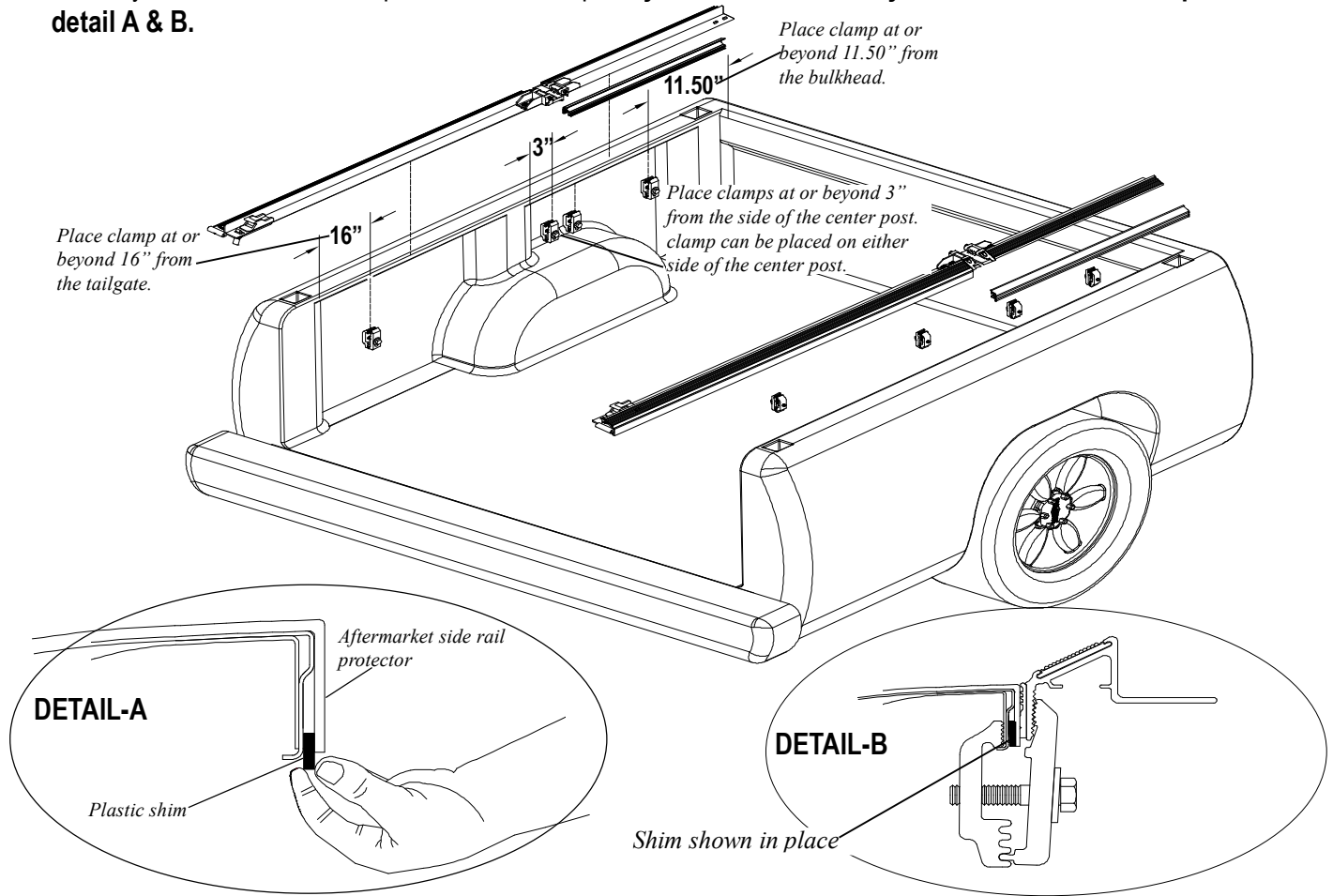

- 2** Next install the TruXedo Deuce rails. Refer to the step-1 in the Deuce owners manual for correct position of the rail front to back. Hold rail level while clamping. Repeat steps 1-2 for the passenger side.

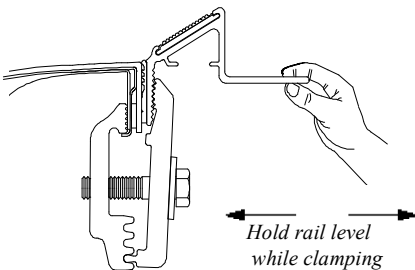

### CAUTION

Tighten clamp assemblies securely on side rails before driving vehicle.



### CAUTION

Note: If your truck has aftermarket or factory side rail protectors, use supplied plastic shims. Failure to do so may cause rail to not sit level and or could cause damage to the vehicle. See detail A & B.