

# NOTICE

## 2007 AND NEWER GM CLAMP INSTALLATION SPECIAL INSTRUCTIONS



### CAUTION

Incorrect clamping can cause damage to the vehicle. Clamp ONLY where TWO layers of sheet metal are present.

- 1** **Correct Clamping locations:** Place clamps in the locations shown below. See owners manual for positioning the side rails correctly. With side rail held in place, attach clamps. If your truck has factory or aftermarket side rail protectors see detail A & detail B.

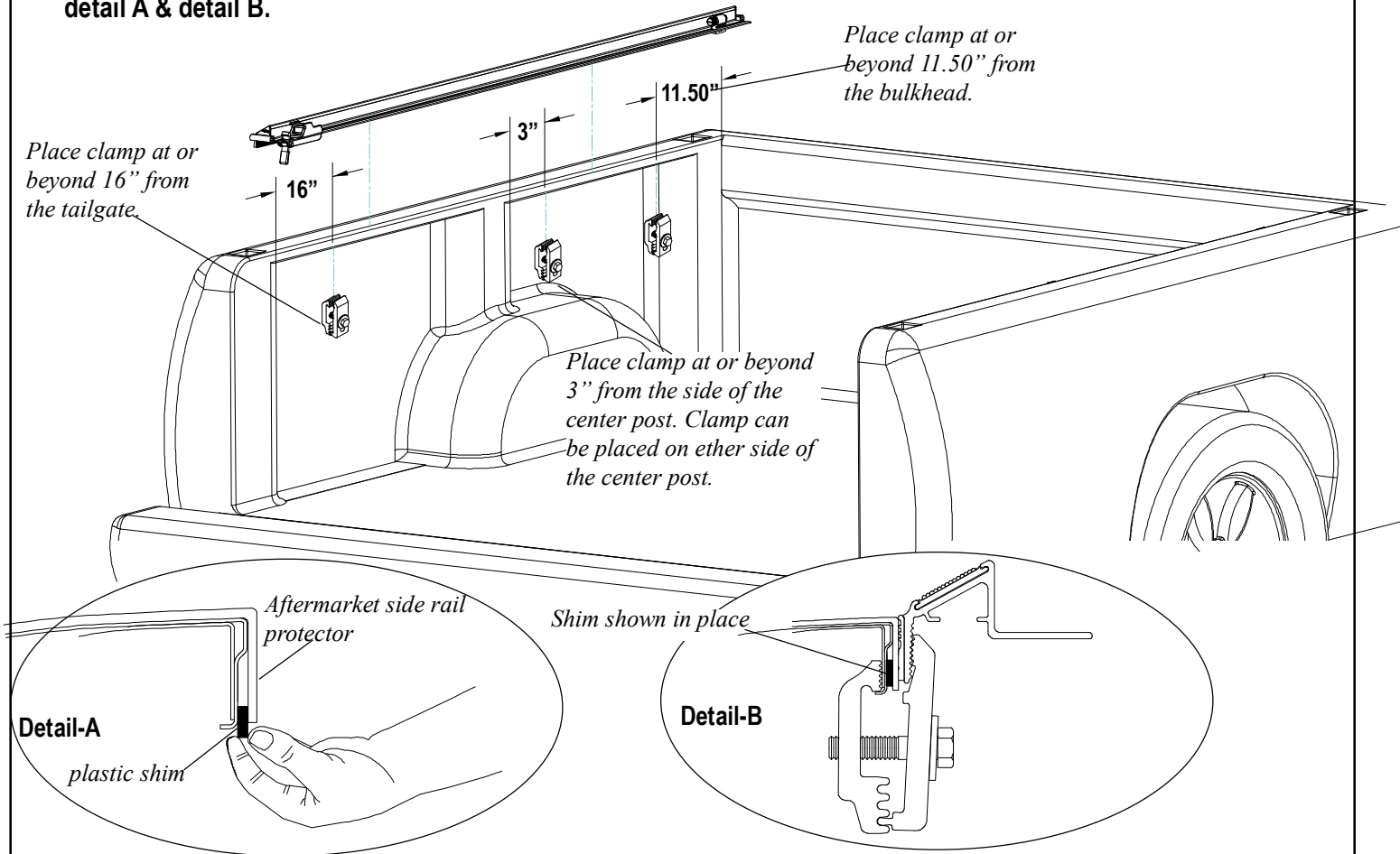

- 2** Next install the TruXedo rail. Refer to the owners manual for correct position of the rail front to back. Hold rail level while clamping.

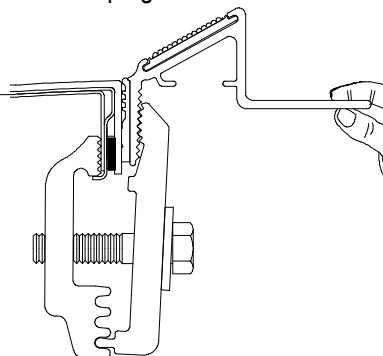

### CAUTION

Note: If your truck has aftermarket or factory side rail protectors, use supplied plastic shims. Failure to do so may cause rail to not sit level and or could cause damage to the vehicle. See detail A & B.

**3**

Repeat step 1-2 for installing the passenger side rail and clamps. Refer to the owners manual for correct position of the rail front to back. Hold rail level while clamping.



### CAUTION

Tighten clamp assemblies securely on side rails before driving vehicle.

by TruXedo, Inc.

P.O. Box 1078, 2209 Kellen Gross Dr., Yankton, SD 57078

Phone: 877- 878-9336 • Fax: (605) 664-9304 [www.truxedo.com](http://www.truxedo.com)

# TRUXEDO®

P/N 1116999 Rev H